

Memristics: Memristors, again?

From Chinese aesthetics of the Fourth Element to DARPA's SyNAPSE

Rudolf Kaehr Dr.

Copyright ThinkArt Lab ISSN 2041-4358

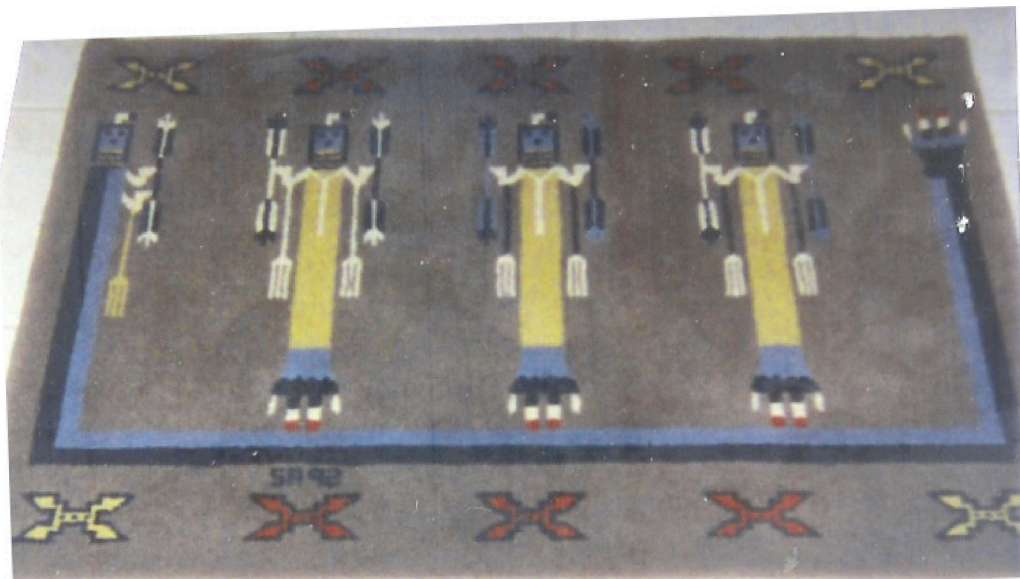
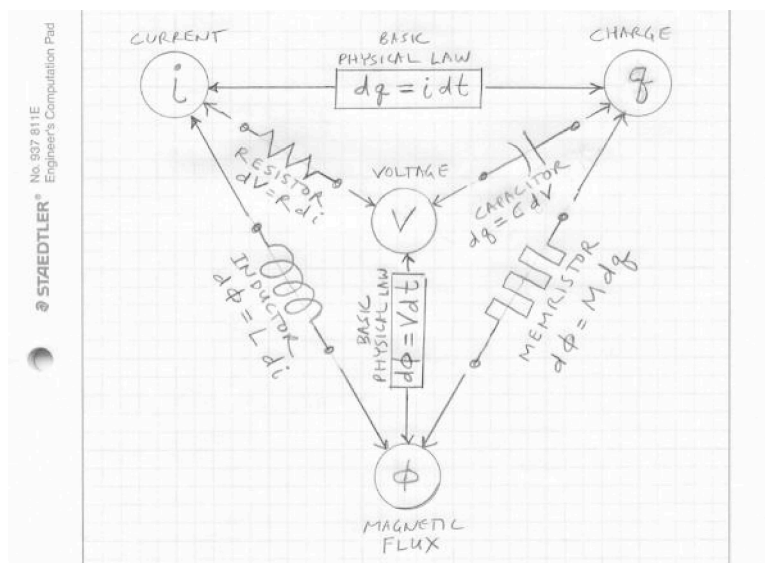

Abstract

This blog-entry gives a first, albeit short critical reflection on the concepts of memristive systems and the history of similar movements. This entry is more or less a collection and compilation of theoretical and propagandistic citations about the future of memristive technology as it can be found in online publications and videos. My own focus is on a possible interplay between memory and computing functions, at once, at the same place and time. A new kind of complementarity between computation and memory on a single chip without retarding buffering conditions, is contemplated. This is a *work in progress*, hence I' m adding some new informations and speculative constructions.

1. Memistor, memristor and SyNAPSE

1.1. DARPA's interventions

The first time I had the honour to participate in a similar inauguration was in 1988 at the first annual meeting of the INNS (International Neural Networks Society) in Boston, organized by Harold Szu from DARPA.

It was an enormously powerful event during an Indian Summer week, perfectly organized and for that reason didn't offer much space for improvised critical and meta-theoretical reflections. As a contemplative contrast I visited the Boston Computer Museum.

I had the chance to talk to Harold Szu in Boston, and received a friendly encouragement to continue with my work in Germany. But my approach was obviously far too strange to be included into the powerful new movement of neural network designs.

Nevertheless I got some funding in Germany to continue my project of a "*Theory of Living Systems*", at my former Institut für Theoretische Biowissenschaften, within and beyond the neural network paradigm.

Neither was Bernard Widrow given enough time at this mega-event to report from his historical results from the time of the very first neuro-technological "boom" in the 60s, his invention of the "*memistor - resistor with memory*". Sounds familiar? The movement was interested in the future only and missed to learn from the past. Approaches like Second-Order Cybernetics and autopoiesis had been totally unknown to the enthusiasts of the new neural network community, and Artificial Intelligence had just become obsolete (Minsky's decree, the Mansfield Amendment (1969), AI-winter).

The success of the new artificial neural networks, from neuro-cybernetics to neuroaesthetics, nevertheless, was and still is enormous and has changed our life radically - in peace and war.

Bernard Widrow's memistor

A new circuit element called a "memistor" (a resistor with memory) has been devised that will have general use in adaptive circuits. With such an element it is possible to get an electronically variable gain control along with the memory required for storage of the system's experiences or training. Experiences are stored in their most compact form, and in a form that is directly usable from the standpoint of system functioning. The element consists of a resistive graphite substrate immersed in a plating bath. The resistance is reversibly controlled by electroplating.

The memistor element has been applied to the realization of adaptive neurons. Memistor circuits for the "Adaline" neuron, which incorporate its simple adaptation procedure, have been developed. It has been possible to train these neurons so that this training will remain effective for weeks. Steps have been taken toward the miniaturization of the memistor element. The memistor promises to be a cheap, reliable, mass-producible, adaptive-system element.

<http://nanomorphware.blogspot.com>

We didn't just get cyberwar with drones to kill in white collar but also small towns in England got their speaking observation cameras, intelligent CCTV, so that our youngsters get warned by the observing camera that an ASBO is on the way. Unfortunately it was "forgotten" to implement such controlling mechanism into the financial system and the Wall Street activities.

A new hype or a new spring?

Now, a new wave, with similar futuristic promises and enthusiasm, has just started with DARPA's SyNAPSE program, supporting mainly the success of HP's realization of Leon Chua's *memristor* concept.

"The vision for the Systems of Neuromorphic Adaptive Plastic Scalable Electronics (SyNAPSE) program is to develop electronic neuromorphic machine technology that scales to biological levels".

<http://www.darpa.mil/dso/thrusts/bio/biologically/synapse/index.htm>

A kind of a general compilation of the hype is written, lately, by Todd Hoff from Highscalability. "*How will memristors change everything?*"

<http://highscalability.com/blog/2010/5/5/how-will-memristors-change-everything.html>

Entity/process versus *différance*

But Chua's *memristor* is a radically different beast than Widrow's memistor from the 60s. Also there had been at this time profound work in second-order cybernetics at the *Biological Computer Laboratory*, Urbana, Ill under Heinz von Foerster (Memory without Record), the first established neuro-boom in cybernetics (McCulloch, Ashby) was strictly classical and embedded in entity-ontology.

"However, a resistor with memory is not a new thing. If taking the example of non-volatile memory, it dates back to 1960 when Bernard Widrow introduced a new circuit element named the memistor (Widrow et al. 1960). The reason for choosing the name of memistor is exactly the same as the MR, a resistor with memory.

The memistor has three terminals and its resistance is controlled by the time integral of a control current signal. This means that the resistance of the memistor is controlled by charge. Widrow devised the memistor as an electrolytic memory element to form a basic structure for a neural circuit architecture called ADALINE (ADaptive LInear NEuron), which was introduced by him and his postgraduate student, Marcian Edward 'Ted' Hoff (Widrow et al. 1960).

However, the memistor is not exactly what researchers were seeking at the nanoscale. It is just a charge-controlled three-terminal (transistor) device. In addition, a two-terminal nano-device can be fabricated without nanoscale alignment, which is an advantage over three-terminal nano-devices (Lehtonen & Laiho 2009). Furthermore, the electrochemical memistors could not meet the requirement for the emerging trend of solid-state integrated circuitry."

<http://rspa.royalsocietypublishing.org/content/early/2010/03/12/rspa.2009.0553.full#sec-7>

The memristance phenomenon of memistors is not an entity but is much more a sort of Derrida's "*différance*" where you don't hear the "a". Chua's *memristor* is a radically new mem(r)istor where you don't hear the "r". It is hidden in the nanosphere and therefore it has taken a while to discover it, albeit it was always among us.

What does *différance* 'mean'? The French word *différer* means: "to defer" and "to differ" at the same time. It is seen as the at-once-ness of making a difference and "defer" it. To "differ" has a connection to *compute*, *defer* is connected to *store*. Hence, by this hint, *différance* gives conceptual clues to an understand of the so called "simultaneity of computation and memory".

<http://www.stanford.edu/class/history34q/readings/Derrida/Differance.html>

Chua's fourth electronic principle and element could have been detected by the grandfathers of electronics too. But as we know today, it was well hidden in the nanosphere and has shown itself only as annoying disturbance. But there is another strong reason why it wasn't in the focus. Classical systems theory is blind for its own difference, i.e. its own environment. There might be systems with environments, but the very concept of a system is without environment.

Surpassing systems theory

A further hint for a deeper understanding of memristics as a new technological approach might be given by Kent Palmer's conceptual work for a fundamental understanding of the "beyond" of systems. At a first glance, there is no doubt that our "holy trinity" of resistors, capacitor and inductors are defining a system. It is even historically correct to mention that systems theory has its roots in such trinity. What's beyond such a system and what nevertheless was always "at work" is its memristivity as its "meta-system". An approach to understanding the "otherness" of systems is developed by Kent Palmer. Another approach can be seen in my own work on *Diamond Category Theory*.

<http://www.thinkartlab.com/pkl/lola/Diamond-Category-Theory.pdf>

"Our view is based on a radical critique of Systems Theory which extends it in a new and hitherto unthought direction. We call that direction *Meta-systems Theory*. Meta-systems theory is the *inverse dual* of Systems Theory.

"We use the term '*meta*' in the sense of beyond. Here the dual of the System is considered what is beyond or outside of the system. Metasystems theory is different from the normal idea that a system has a boundary and that what ever is beyond the system is non-system. Meta-systems theory posits that there is an organization to what is beyond the system that is *different* from the system itself."

Kent Duane Palmer, EMERGENT DESIGN

Explorations in Systems Phenomenology in Relation to Ontology, Hermeneutics and the Meta-dialectics of Design, 2009

<http://arrow.unisa.edu.au:8080/vital/access/manager/Repository/unisa:42392>

Some recalls in electronics

1.2.1. Electrical units

Recall electronics at a highly official place: DOE FUNDAMENTALS HANDBOOK

<http://hss.energy.gov/nuclearsafety/ns/techstds/standard/hdbk1011/h1011v1.pdf>

Electrical Units Summary

<u>Parameter</u>	<u>Measuring Unit</u>	<u>Relationship</u>
Voltage	volt (V or E)	$E = I \times R$
Current	amp (I)	$I = \frac{E}{R}$
Resistance	ohm (R or Ω)	$R = \frac{E}{I}$
Conductance	mho (G or \mathcal{U})	$G = \frac{I}{R} = \frac{I}{E}$
Power	watt (W)	$P = I \times E$ or $P = I^2 R$
Inductance	henry (L or H)	$V_L = -L \left(\frac{\Delta I}{\Delta t} \right)$
Capacitance	farad (C)	$C = \frac{Q}{E}$ (Q = charge)

1.2.2. Analog/digital and learning

Digital

Not the computer is learning but the software program of the computer.

Time by clock and clock pulse.

Sequential

NOR, NAND gates

volatile

easy programmable

"Digital circuits are made from analog components. The design must assure that the analog nature of the components doesn't dominate the desired digital behavior. Digital systems must manage noise and timing margins, parasitic inductances and capacitances, and filter power connections."

Analog

Parallel

Non-timed, no clocked time

difficult to program

Analog/digital modes

"A memristive device can operate in both digital and analog modes, each of which has different applications."

In *digital mode*, it could replace today's solid-state memories (Flash) with much faster and less expensive nonvolatile random access memory (NVRAM).

Longer term, in its *analog mode*, the memristor could possibly enable computers that "learn" what you want."

http://www.hpl.hp.com/news/2008/apr-jun/engineering_memristor.html

Learning: emulation vs. simulation

"Any learning a computer displays today is the result of software," says Yang. "What we're talking about is the computer itself - the hardware - being able to learn."

http://www.hpl.hp.com/news/2008/apr-jun/engineering_memristor.html

1.3. Memristics: Catching memristance

1.3.1. Some more electronics

"resistors connect voltage and current, inductors connect flux and current, and capacitors connect voltage and charge.

But one equation is missing from this group:

the relationship between *charge* moving through a circuit and the magnetic *flux* surrounded by that circuit-or more subtly, a mathematical **doppelganger** defined by Faraday's Law as the time integral of the voltage across the circuit."

"We now know that memristance is an **intrinsic** property of any electronic circuit. Its existence could have been deduced by Gustav Kirchhoff or by James Clerk Maxwell, if either had considered nonlinear circuits in the 1800s. But the scales at which electronic devices have been built for most of the past two centuries have prevented experimental observation of the effect. It turns out that the influence of memristance obeys an inverse square law:"

<http://www.ieeeahn.org/wiki/index.php/Memristor>

Clive Akass' compilation

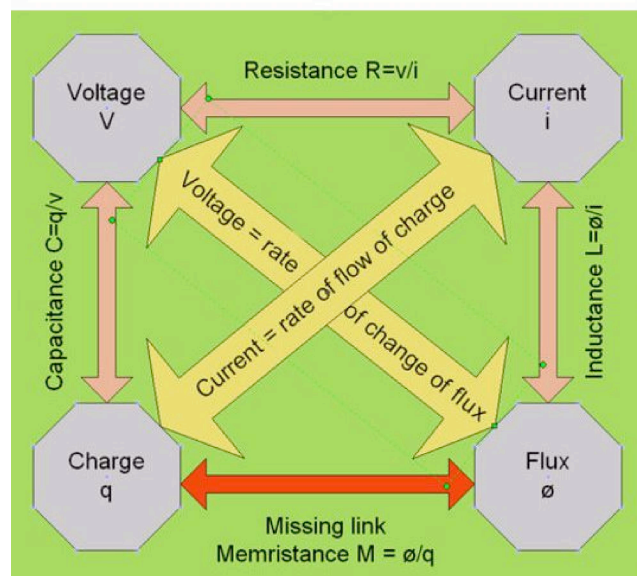

Another presentation is given by Nit Kurukshetra et al, *Memristor: The Missing Link discovered*

"Chua noted that there are six different mathematical relations

connecting pairs of the four fundamental circuit variables: electric current i , voltage v , charge q and magnetic flux Φ . One of these relations, the charge is the time integral of the current, is determined from the definitions of two of the variables, and another, the flux is the time integral of the electromotive force, or voltage, is determined from Faraday's law of induction. Thus, there should be four basic circuit elements described by the remaining relations between the variables. The three known circuit elements are described by the following equations:-

$$\begin{aligned} dv/di &= r \text{ incremental resistance} \\ d\Phi/di &= L \text{ inductance} \\ dv/dq &= 1/C \text{ inverse capacitance.} \end{aligned}$$

The 'missing' element—the memristor, with *memristance* M , provides a functional relation between *charge and flux* as given under $d\Phi/dq = M(q)$ memristance."

Leon Ong Chua (Chinese: 蔡少堂; born June 28, 1936) studying electronics, didn't feel comfortable with "*The holy trinity: resistors, inductors and capacitors, are three and one at the same time.*" (Nicolau Warneck)

There was something missing to please his aesthetic consciousness. And yes there was a gap. There always was this gap. But that didn't matter at all because this gap was hidden in the nanosphere and, as we all know, the hole trinity is governing the realm of macro- and micro-spheres, only. There has to be four elements and their 6 relationships and not only three elements and 5 relationships to fulfil the harmonic symmetry of Leon Chua's aesthetics. The figure had to be closed in harmony.

Finally, the picture was completed and the missing formula found:
Leon Chua has discovered/created mathematically the fourth fundamental element in electronics: the *memristor* :
提出了憶阻器 .

The original paper

LEON O. CHUA, *Memristor-The Missing Circuit Element*

"This paper presents the logical and scientific basis for the existence of a new two-terminal circuit element called the memristor (contraction for memory resistor) which has every right to be as basic as the three classical circuit elements already in existence, namely, the resistor, inductor, and capacitor.

Although the existence of a memristor in the form of a physical device without internal power supply has not yet been discovered, its laboratory realization in the form of active circuits will be presented in Section II."

http://www.lane.ufpa.br/rodrigo/chua/Memristor_chua_article.pdf

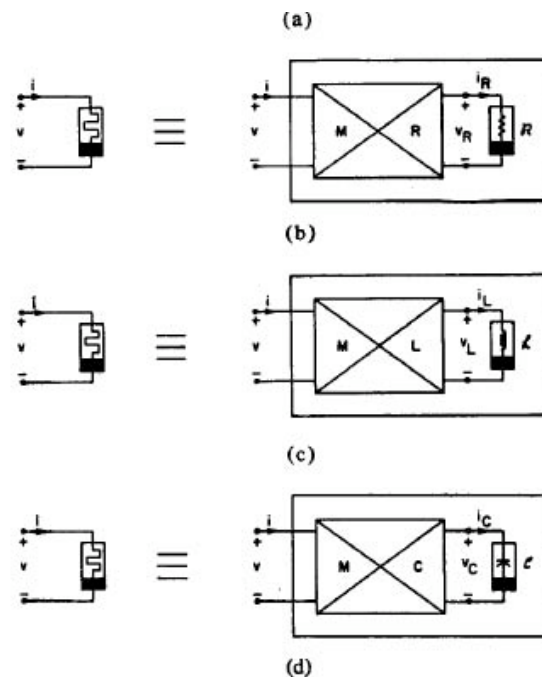

"From the logical as well as axiomatic points of view, it is necessary for the sake of *completeness* to postulate the existence of a fourth basic two-terminal circuit element which is characterized by a φ - q curve. This element will henceforth be called the *memristor* because, as will be shown later, it behaves somewhat like a nonlinear resistor with memory." (Chua, p. 3)

What was still missing in 1971 was a technical *realization* of the element as a new '*electronic component*' to transform it from an aesthetical '*dalliance*' into a revolutionary technical device.

Interestingly, the memristor had at least three appearances on stage; Memistor, Memristor as a concept and Memristor as a HP invention.

The memristor is not simply one more electronic element among others but the *closure* of the system of electronics as we know it as a whole. There are now 4 elements, not three. But these 4 elements and their 6 relationships are closing the systematics of the electronic table of elements. Before the invention of the memristor there was still a systematical gap in the table of elements.

OK, this is only the start for a new epoch of computational technology.

Memristor minds: The future of artificial intelligence

"EVER had the feeling something is missing? If so, you're in good company. Dmitri Mendeleev did in 1869 when he noticed four gaps in his periodic table. They turned out to be the undiscovered elements scandium, gallium, technetium and germanium. Paul Dirac did in 1929 when he looked deep into the quantum-mechanical equation he had formulated to describe the electron. Besides the electron, he saw something else that looked rather like it, but different. It was only in 1932, when the electron's antimatter sibling, the positron, was sighted in cosmic rays that such a thing was found to exist.

In 1971, Leon Chua had that feeling. A young electronics engineer with a penchant for mathematics at the University of California, Berkeley, he was fascinated by the fact that electronics had no rigorous mathematical foundation."

<http://www.newscientist.com/article/mg20327151.600-memristor-minds-the-future-of-artificial-intelligence.html>

Today we have Peter Higgs waiting in an Edinburgh pub for his Higgs boson, the God particle, he postulated theoretically in October 1964, to be discovered at the Large Hadron Collider (LHC) in Geneva. Unfurtantely, I couldn't find him during my stay in Edinburgh, probably he was enjoying at that time the Lake of Geneva.

Towards the memristor

"Circuit theory, along with many other electromagnetic systems, can be explained by the zero-order and first-order Maxwell equations for which one obtains quasi-static fields as the solutions. The three classical circuit elements resistor, inductor and capacitor can then be explained as electromagnetic systems whose quasi-static solutions correspond to certain combinations of the zero-order and the first-order solutions of equations (4.11)-(4.14)

However, in this quasi-static explanation of circuit elements, an interesting possibility was unfortunately dismissed (Fano et al. 1960) as it was thought not to have any correspondence with an imaginable situation in circuit theory. This is the case when both the first-order electric and the first-order magnetic fields are not negligible. Chua argued that it is precisely this possibility that provides a hint towards the existence of a fourth basic circuit device."

As the curl operator does not involve time derivatives, and \mathcal{F} is defined over space coordinates, equation (4.18) says that the first-order fields \mathbf{H}_1 and \mathbf{E}_1 are related. This relation can be expressed by assuming a function \mathcal{F} and we can write

$$\mathbf{E}_1 = \mathcal{F}(\mathbf{H}_1). \quad 4.19$$

Now, equation (4.17) can be re-expressed by using equation (4.19) as

$$\mathbf{D}_1 = \mathcal{D} \circ \mathcal{F}(\mathbf{H}_1), \quad 4.20$$

where the \circ operator is the composition of two (or more) functions. Also, as \mathcal{B} is a one-to-one continuous function, equation (4.16) can be re-expressed as

$$\mathbf{H}_1 = \mathcal{B}^{-1}(\mathbf{B}_1). \quad 4.21$$

Inserting from equation (4.21) into equation (4.20) then gives

$$\mathbf{D}_1 = \mathcal{D} \circ \mathcal{F} \circ [\mathcal{B}^{-1}(\mathbf{B}_1)] \equiv \mathcal{G}(\mathbf{B}_1). \quad 4.22$$

"Equation (4.22) predicts that an instantaneous relationship can be established between \mathbf{D}_1 and \mathbf{B}_1 that is realizable in an MR."

<http://rspa.royalsocietypublishing.org/content/early/2010/03/12/rspa.2009.0553.full>

Is non-linearity enough?

Critical remarks

It might be argued that the relationship established between \mathbf{D}_1 and \mathbf{B}_1 is not thematizing the categorical difference between electronics and nanoelectronics in the formula itself. Despite the fact that the deduction presumes "*non-linear material for which the first-order fields become related*", the categorical or structural difference between these two domains, micro and nano, is not reflected by the structure of the formula as such. The formula is represents a deduction out of the electronic premises albeit under *non-linear* conditions showing the formal existence of the relation between \mathbf{D}_1 and \mathbf{B}_1 . But not more. That is, the structural difference between micro- and nanosphere has no representation in the formula. Therefore, the formula is based on a homogenization and leveling of a fundamental difference.

The ambiguity of the memristor entity, to be the fourth and *closing* element of electronics, and simultaneously, being the *opener* of the field of nanoelectronics, with mem-ristance, mem-capacitance and mem-inductance, to restrict to the immediate extensions, is not deducible by the formula.

The question is: *Is non-linearity enough to open up a new era in electronics?*

It is even questionable if such a deduction of the open/close characteristics of memristance is possible in the framework of the math of electronics, linear or non-linear.

The method applied by Chua is *substitution* and *transformation* of the basic electronic formulas guided by the feeling for harmony.

A diamond interpretation might *speculate* (!) on two solutions of the formula, i.e. on two constructions as outcomes:

1. the *categorical* or functional result as $\mathcal{D} = \mathcal{G}(B_1)$ in the sense of Chua,
2. the *saltatorial* or complementary result as: $\text{salt}(\mathcal{D} \circ \mathcal{F}(H_1)) \implies (d \longleftarrow f(h_1))$,

The hetero-morphism $(d \longleftarrow f(h_1))$ is the saltatorial *complement* of $(\mathcal{D} \circ \mathcal{F}(H_1))$, i.e. $\mathcal{G}(B_1)$,

hence $\overleftarrow{g}(b_1)$.

3. the *diamond*

$$\text{result : } (\mathcal{D} \circ \mathcal{F}(H_1)) : \mathcal{D} = \left(\begin{array}{l} 1. \mathcal{G}(B_1) \text{ by substitution} \\ \overleftarrow{\hspace{1.5cm}} \\ 2. \overleftarrow{g}(b_1) \text{ by diamondization} \end{array} \right)$$

<p>Diamond of memristance</p> $(\mathcal{D} \circ \mathcal{F}(H_1)) \implies \mathcal{D} = \mathcal{G}(B_1) \mid \overleftarrow{g}(b_1)$

The main argument for a saltatorial approach is supported by the observation that the composition of functions in Chua’s formula are not reflecting the matching conditions of the composition.

The diamond approach might be understood as a categorification of the Chua’s functional approach but involved with the diamond theoretic decision to opt for the *complementary* morphisms (hetero-morphisms) based on the “*in-sourcing*” of the matching conditions of the composition of morphisms.

Hence, what might it be that is not thematized in Chua’s formula itself? Obviously, what isn’t represented by the formal are the pre-requisites, the premises and suppositions of the formula, which are stated ‘outside’ the formula. And this are exactly the preconditions of *nanosphere* and *nonlinearity*. Hence, the logical ‘environment’ or context between \mathcal{D} and B is

the nonlinearity of the nanosphere, i.e. "[...] the device is made from nonlinear material [...]."

1.3.2. Closure and self-referentiality

The diagram for memristive systems shows, again, in an aesthetic way, next to the harmonic closure of the fourth elements, a *self-referentiality* not yet considered, but drawn, in the theory of the fundamentals of memristics. This kind of self-referentiality is not captured by the snake metaphor, Uroborus, of second-order cybernetics, but demands for a chiasm of creativity where circularity and recursion is embedded secondarily.

The fourth element is not simply an additional element to the three basic element but is enclosing the trinity, creating its wholeness and uniqueness. Both together are not closing the electronic system but opening up the memristive system of dissipative nano-electronic developments.

In mythological and alchemistic terms the fourth is described by Marie-Luise Frantz as the unit in relation to the primordial one:

"Die Drei als Einheit gesehen und in Beziehung zur Ureins gebracht, ist das Vierte, welches nicht etwa progressive 'entsteht', sondern rückblickend als von jeher existent erkannt wird."

http://www.vordenker.de/ggphilosophie/eva-meyer_zum-phantasma-der-selbstgeburt.pdf

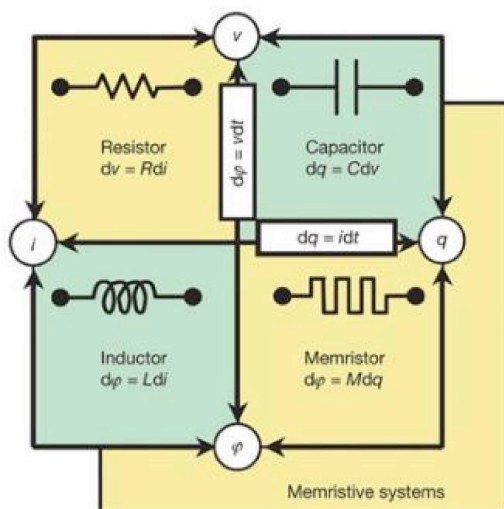

The memristive systems paradigm in a formalized Navaho pattern of the four goddesses.

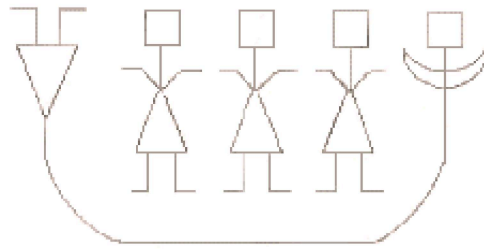

<http://tap3x.net/EMBTI/navaho3.g>
<http://www.orientalrugdesigns.com/index.php?cPath=27>

How to escape memristics?

Strategies to escape a closure of a paradigm are appearing in history on many levels of consciousness and instinctive reactions of refutation. The most radical thinkers of the last century, especially Jaques Derrida, Philip Sollers, Julia Kristeva, have spent a lot of virtuosity to prevent a *closure* of the paradigm of the openness of thinking. The fear to fall back into the dark ages of totalitarianism (and death, the 4) blinded them for new ways of thinking beyond the game of open/closed world-views.

One nice strategy was found in the exploitation of the mythological figure of the *Meander*. The Meander is closed but to the crucial point and open iteratively without end.

A refutation of memristics is invited to be aware of this clever strategy. But first, some exercises in the conceptualization of the field would be recommended.

As all Western theories, electronics has its *dual* or opposite formulation too. Probably not much studied but theoretically unavoidable.

Electronics: (α, β) , with $\alpha = (q, V, i, \Phi)$ dual $(\Phi, i, V, q) = \beta$.

A formal theory of *application* of “conceptual” electronics is then studying the iterativity (in time) of the dual (α, β) , i.e. $(\alpha, \beta)^{(n)} \implies (\alpha, \beta)^{(n+1)}$.

Meanders of conceptual electronics

1. $(\alpha, \beta) \in \text{Mean}$

2. $(\alpha, \beta)^{(n+1)} \in \text{Mean} \implies (\alpha, \beta)^{(n)} \circ (\alpha, \beta)^1 \in \text{Mean}$

For $\forall i, j: (\alpha, \beta)^i \cap (\alpha, \beta)^j = \emptyset$, for $i, j \in \mathcal{N}$

Meander example

$$(\alpha, \beta)^1 = \begin{pmatrix} V_1 & - & i_1 & \square & i_2 & - & V_2 \\ | & X & | & \square & | & X & | \\ q_1 & ? & \Phi_1 & - & \Phi_2 & ? & q_2 \\ \square & \alpha & \square & \square & \square & \beta & \square \end{pmatrix}$$

$$(\alpha, \beta)^2 = \begin{pmatrix} V & - & i & \square & i & - & V & V & - & i & \square & i & - & V \\ | & X & | & \square & | & X & | & | & X & | & \square & | & X & | \\ q & ? & \Phi & - & \Phi & ? & q & q & ? & \Phi & - & \Phi & ? & q \\ \square & \alpha & \square & \square & \square & \beta & \square & \square & \alpha & \square & \square & \square & \beta & \square \end{pmatrix}$$

The Meander-Strategy is save insofar as it conserves the time structure of linear iterability.

Combined with the idea of a *duality* in electronics, the question of the dual of memristics has to be conceived. Such a “duality” of memristics gets confronted systematically with the fundamental concept of *complementarity*, too.

Memristive systems as higher-order concepts in the SPICE model

"In the light of th above, Fig. 1 offers another view on the relationship between the passive R, L, and C elements and their memory versions. This figure can be likened to a house with two floors, the floor of passive non-memory R, C, and L elements, and the upstairs of mem-elements, containing the memristor, memcapacitor, and meminductor. In fact, the fourth fundamental passive element, the memristor, postulated by Chua in [1] on the basis of the well-known "four-square" symmetry, is located on the higher floor of the mem-elements. We can wonder whether somebody will find other practically exploitable higher-order elements on some other floor."

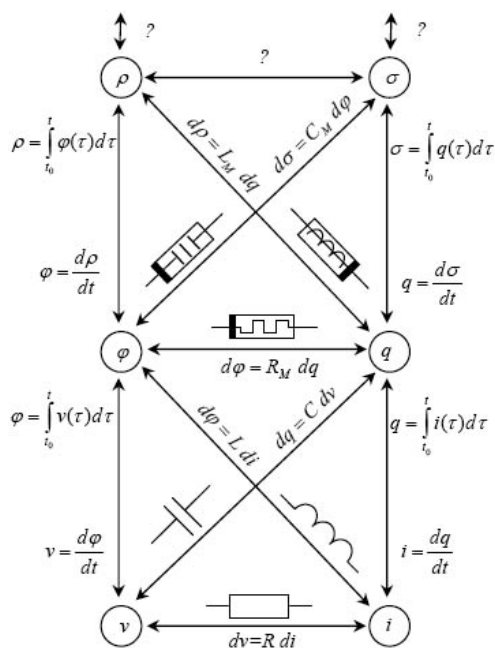

"By virtue of a detailed classification of the so-called memsystems and their special subclasses such as memristor, memcapacitor and meminductor, it is shown that the memristor supplements the system of passive R, C, and L elements in the sense of the missing link between flux and charge, but it also holds its position within the set of passive mem-elements which is connected to the conventional memory-less elements in the sense of the diagram in Fig. 1." (Dalibor Biolek et al, p. 4) Dalibor Biolek et al, SPICE Modeling of Memristive, Memcapacitative and Meminductive Systems

www.vabo.cz/stranky/biolek/veda/articles/ECCTD09_2.pdf

Double character

This statement, "the missing link between flux and charge, but it also holds its position within the set of passive mem-elements" clearly supports my speculations about the double 'character', i.e. the double functionality of the

memristor as it was introduced first by Leon Chua as the 'missing circuit element' and simultaneously as the opening up the memristive systems.

This tricky and ambiguous situation of the memristor localization as belonging to the first floor and at once to the second floor, opening up the second floor tectonics based on the first floor, can be found in the basic construction of products in diamond category theory.

This shall be exemplified with the categorical product construction " $a * b$ " and its diamondization.

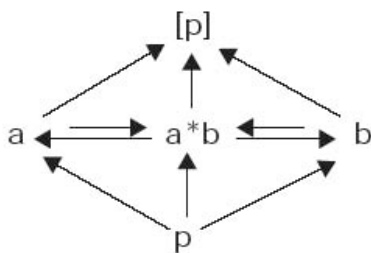

The categorical product " $a * b$ " is founded in p . The categorical product is based on the inverse product, the thematization of the compositor, as a morphogram $[p]$. The core elements of the diagram, a , b , $a * b$, have a double meaning. They belong simultaneously to categories and to saltatories. Insofar, they define the structure of the morphogram $[p]$.

As an example, we can think of a logical disjunction " $a \vee b$ ", which is based on its constituents " a " and " b " as core elements. Those together can be inverted to the hetero-morphism $[p]$, which defines the morphogram of the binary disjunction as the operativity of the operator " \vee ", but concretized in its complication, as a binary action, by the constituents " a " and " b ".

Because morphograms can be conceived as 'inversa' of compositions, and are generating a generalization of the composition of morphisms, they are representing a permutation-invariant class of compositions.

In the example, the morphogram $[p]$ is representing the disjunction " avb " as well as all negations of it " $\neg(avb)$ ".

Hence, again, morphograms are negation-invariant patterns.

If a product composition is called a process (Baez) then the complementarity of the process is the form, i.e. the formation or structuration of the process, hence inscribed as the morphogram of the process.

Obviously, on the first floor of the electronic tectonics, objects are self-identical and therefore negation-dependent. Processes on the second floor are on a nanoscale, therefore not self-identical in the classical manner, and thus negation-invariant.

Higher order floors

"We can wonder whether somebody will find other practically exploitable higher-order elements on some other floor."

One might speculate that, because the occupation of the second floor is establishing a connection to the nano-scale of electronics and its first level of nonlinearity, that a third level might uncover other domains of nanoelectronics and further elaborated nonlinear situations. It seems that there are no physical or conceptual reasons to stop at the second level of the hierarchy of memristive systems. Neither are there any reasons not to build more spaces at the established levels, i.e. to enlarge the heterarchical organization of memristive systems.

Hans Primas, Quantum physics

Again, I would like to recall Hans Primas statement about the nature of quantum physics. This anti-reductionist position should be applied on memristive systems. There are no "elements" in quantum physics, like in micro-electronics, but *patterns of behavior* which have to be discovered. Hence, the domain of memristive systems and marked patterns are not restricted to some new elements, like memristor or other mem-elements.

"Modern quantum mechanics put an end to atomism and hence to reductionism: The so-called "elementary particles" (such as electrons, quarks, or gluons) are patterns of reality, not building blocks of reality. They are not primary, but arise as secondary manifestations, for example as field excitations, in the same sense as solitons are localized excitations of water, and not building blocks of water." (Hans Primas)

On the other side, quantum phenomena are involved with *time-structures* unknown to classical physics. Therefore, it seems to be natural to think that the new field of memristive systems has first of all to study the different temporal structures of quantum events and to develop from there new distinctions to build new memristive devices.

In Fundamental Physical Theories There is No Now

"All really fundamental physical dynamical laws are invariant under time translation and time reversal. Moreover, the concept of the "now - the brief interval that divides the past from the future - is absent in all

fundamental mathematical formulations, both in classical physics and in quantum physics. That is, in a context-independent ontic description there is no physical basis for the the distinction between past and future."

(Hans Primas)

<http://www.mindmatter.de/mmpdf/primas.pdf>

Now as happenstance

"Chinese logical reasoning instead foregrounds the element of time as *now*. Time, then, plays a crucial role in the structure of Chinese logic."

http://www.thinkartlab.com/CCR/2006_09_01_rudys-chinese-challenge_archive.html

Mem-systems as physical higer-order learning systems

First-order concepts of electronics, i.e. the 1-triple (I, R, C), are *zero-learning* concepts ('supervised learning'). They are regulating the flow according to their definitions and programs; and are in a state but don't *have* their states. Hence, they don't have access to their own states to re-program the states.

Second-order concepts of nano-electronics, i.e. the 2-triple mem-(I, R, C), are *first-order learning* concepts (unsupervised learning). They 'memorize' their state, therefore are learning their state in contrast to having a state, like the first-order concepts without learning.

Certainly, this will open up enormous advances in developing, again, learning machines. But now from *button-up* from the hardware, i.e. from the material involved, instead of the programs applied.

Third-order concepts of nano-electronics, i.e. the 3-triple 'mem of mem-(I, R, C)', are *second-order learning* concepts (learning to learn). They are able to 'memorize' what they 'learned' from the first-order learning situation. Hence, they learn to learn.

<http://www.vordenker.de/ics/poly.htm>

Symbolic diagrams

- first – order elements-

- second – order elements- : - first – order elements
mem- :

- third – order elements |- : | second – order elements |
↕ X ↕
second – order elements |

Memristance as a result of a diamondization

But Chua's invention/discovery seems to be from another planet. The mythological figure of the Navaho goddesses gives a hint how to close the figure while opening it definitively. Not linear dromic iterability but antidromic movements of being past and future at once are the challenge to be accepted for an understanding of the new possibilities of technology.

In other words, classical physical events are a-historical, memristive events are involved with history. But this tells not yet much about the new temporal structure of memristive events. The paradox of memristive temporality seems to be its possible simultaneous 'forwards' and 'backwards' orientation (as in the wording "simultaneously memory and computation"). This is in conflict not only with temporal logic but with logic at all. On the other hand, the structure of historical events are well studied in the early "Geisteswissenschaften" or today humanities (cognitive sciences), but are lacking any operative logic at all.

This strange figure of a simultaneity of a temporal '*forwards and backwards*' (computation+memory) orientation of events is well known in *diamond* category theory. Hence, there is no surprise to see the category of memristance as a *hetero-morphism* in a saltatory of diamond category theory. Saltatories are complementarity mechanisms of categories. With that, and some elaboration, new properties of memristics might be discovered on a strictly conceptual level of construction. After that, the whole game has to be *concretized* down to the engineering terminology and mathematical methods, which, obviously, are not touched in such strategies of diamondizations.

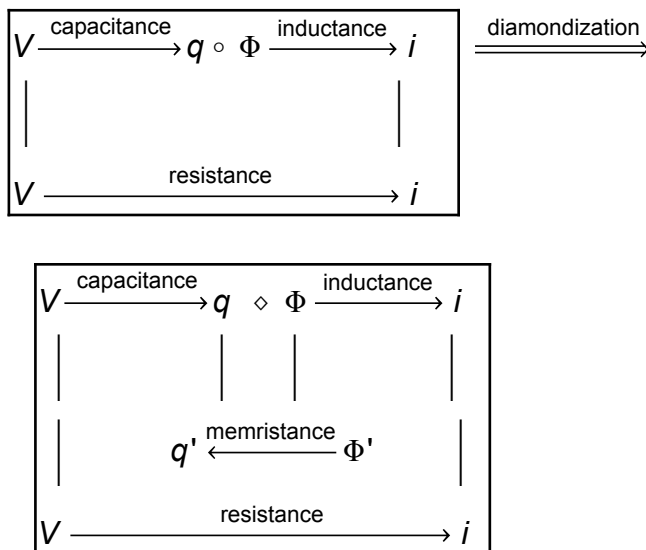

In this example of a model, capacitance is *internally* dual to inductance, and resistance therefore is *complementary* to memristance. The pair (resistance, memristance) is not dual like the pair (capacitance, inductance) because memristance is not set inside the system of electronics of (capacitance, resistance, inductance) but “beyond” such a system, i.e. opening up the ‘*meta-system*’ of the system in the sense of Palmer’s Emergent systems theory. This becomes quickly clear if the modes of composition (categorical versus saltatorial) are studied in more complex situations. Categorical composition is gap-free, saltatorial combinations are involved in ‘jumps’ over gaps. As the example makes it clear enough, *diamondization* is not introducing a meta-system in the sense of classical model theory of logic, cybernetic systems, etc.

Some simple rules of diamondization

$$\left(V \xrightarrow{\text{capacitance}} q \diamond \Phi \xrightarrow{\text{inductance}} i \right) \implies \begin{pmatrix} 1. V \xrightarrow{\text{resistance}} i \\ 2. q' \xleftarrow{\text{memristance}} \Phi' \end{pmatrix}$$

$\left(V \xrightarrow{\text{capacitance}} q \right) \diamond \left(\Phi \xrightarrow{\text{inductance}} i \right)$ <hr style="width: 100%;"/> $V \xrightarrow{\text{resistance}} i \quad \Bigg \quad q' \xleftarrow{\text{memristance}} \Phi'$

Saltatorial "jump"-operation (||)

Resistance and memristance between different systems.

Resistance is ruled by *composition* (◦) of the systems:

$$\left(V \xrightarrow{\text{resistance}} q \right)_1 \circ \left(V \xrightarrow{\text{resistance}} q \right)_2 \implies \left(V_1 \xrightarrow{\text{resistance}} q_2 \right) (3, 4).$$

Memristance is ruled by saltisition (jump ||) between the systems:

$$\left(q' \xleftarrow{\text{memristance}} \Phi' \right)_1 || \left(q' \xleftarrow{\text{memristance}} \Phi' \right)_2 \implies \left(q'_{1} \xleftarrow{\text{memristance}} \Phi'_{2} \right) (3, 4).$$

1.
$$\left(V \xrightarrow{\text{capacitance}} q \diamond \Phi \xrightarrow{\text{inductance}} i \right)_1 \diamond \left(V \xrightarrow{\text{capacitance}} q \diamond \Phi \xrightarrow{\text{inductance}} i \right)_2$$

2.
$$\left(V \xrightarrow{\text{resistance}} q \quad \Bigg| \quad q' \xleftarrow{\text{memristance}} \Phi' \right)_1 \diamond \left(V \xrightarrow{\text{resistance}} q \quad \Bigg| \quad q' \xleftarrow{\text{memristance}} \Phi' \right)_2$$

- 3.

$$\left(V \xrightarrow{\text{resistance}} q \right)_1 \circ \left(V \xrightarrow{\text{resistance}} q \right)_2 \mid \left(q' \xleftarrow{\text{memristance}} \Phi' \right)_1 \parallel \left(q' \xleftarrow{\text{memristance}} \Phi \right)_2$$

4. $\left(V_1 \xrightarrow{\text{resistance}} q_2 \right) \mid \left(q'_{1} \xleftarrow{\text{memristance}} \Phi'_{2} \right).$

Jump – operation

$$\left(V \xrightarrow{\text{capacitance}} q \diamond \Phi \xrightarrow{\text{inductance}} i \right)_1 \diamond \left(V \xrightarrow{\text{capacitance}} q \diamond \Phi \xrightarrow{\text{inductance}} i \right)_2$$

$$\left(V_1 \xrightarrow{\text{resistance}} q_2 \right) \mid \left(q'_{1} \xleftarrow{\text{memristance}} \Phi'_{2} \right)$$

Tour de force

This presentation is using a kind of a "tour de force" strategy because the hidden *matching conditions* are not (yet) explicitly introduced. What nevertheless becomes more clear is the difference of *sequential* (or parallel) gap-free compositions (yuxtapositions) for electronic systems and the *saltatorial* (salto: jump) combinations in memristive systems. With an elaboration of this diamond-theoretical construction, a clear conceptual and paradigmatic *difference* (rupture) between electronic and memristive systems would be established - probably as a *sine qua non* of memristics.

Memristance as an environment

It could be argued that the electronics of (R, C, I), i.e. resistance, capacitance and inductance, is building a (closed) system. Therefore, memristance occurs, conceptually, as an environment of this closed system.

From the point of view of *textemes*, as generalizations of signs, memristance appears as the natural environment of (R, C, I) related to R. On the base of this approach, it is then straightforward to consider environments related to the other aspects, i.e. capacitance and inductance, thus delivering immanently mem-capacitance and mem-inductance.

Distribution of such systems with environments might be mediated to interesting new *compound* structures with compound systems and compound environments of different types.

<http://www.thinkartlab.com/pkl/media/Textems/Textems.pdf>

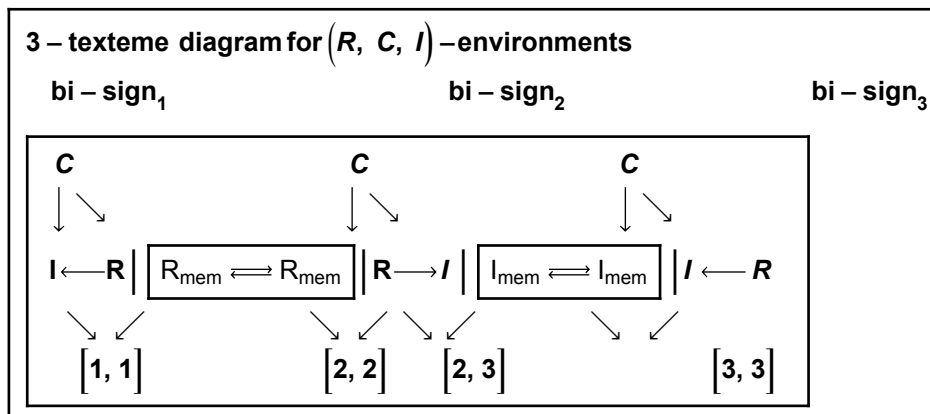

Towards a Bennett III - Chua Debate

There is a kind of a debate on the way about the *existence* of the Chua's fourth element at <http://www.frogheart.ca/?p=898>.

I will comment on this debate in a later paper. But apply what was developed in the previous paragraph.

Here are some further excerpts.

"He also added a few comments about the 'fourth circuit element' debate."

Leon Chua

Memristor = Fourth Element

"For now, it may help you to know that there are two technical reasons why the memristor is the fourth element.

"*First*, one can prove from circuit-theoretic principles that it is impossible to build a memristor using only two-terminal resistors, inductors, and capacitors, even if one uses such active 2-terminal elements as negative resistors, or tunnel diodes. Following the logical principles from Aristotle, it would be only logical to classify the memristor as a different element from the other three.

infinite number of circuit elements

"The *second* reason is even though Part 1 [of the 2002 paper] shows there is an infinite number of circuit elements, and even though all can in principle be built using transistors (this does not contradict my statement above since transistors are 3-terminal devices, while the memristor being a 2-terminal device, should also be realized with 2-terminal devices), only memristors can be built without transistors, op amps, batteries, etc.

All the higher-order elements are *active*, and hence do not exist in nature.

They must be made with active elements and need a power supply. In contrast, the hp memristor is passive and hence non-volatile. This is analogous to chemistry where elements with higher numbers are unstable, and radioactive. Hope above helps."

Thank you Dr. Chua.

<http://www.frogheart.ca/?p=923>

Forrest H Bennett III

> 2.. Is the criterion (or one of them) for defining a new fourth element circuit that someone assigns a unique measurement for the element?

There isn't really a rigorous way to define what a new circuit element would have to look like. But there are three arguments against the idea that a memristor is a 4th circuit element:

Measured in Ohm

First, the weakest argument is that memristance is measured in the same units (ohms) as resistors, whereas the standard 3 circuit elements each have their own units of measure.

Second, a stronger argument is based on what we now know about memcapacitors and meminductors. Now you might be tempted to regard memcapacitors and meminductors as the 5th and 6th new fundamental circuit elements, but nobody does. Why?

If you stand back and look at the actual behavior of these 6 circuit elements, it is very clear that they naturally fall into two groups. One group is the normal resistor, capacitor, and inductor. The other group contains the new memresistor, memcapacitor, and meminductor. There is no way to consider the memristor to be the 4th element of the first group. The unmistakable distinction between these two groups is that the first group are "linear" elements, and the second group are "nonlinear" elements.

Fourth element vs. periodic table

The *third* and strongest argument against the 4th element idea actually comes from Chua's own 2003 paper, "*Nonlinear Circuit Foundations for Nanodevices*", which is a wonderful paper. It actually contains an idea even more exciting than the idea of a "4th element". He shows an entire *periodic table* of circuit elements! Not only that, it's an infinite periodic table of circuit elements!

Now if you look at this periodic table of circuit elements, you will see that they fall naturally into 4 classes. There is one class that contains both capacitors and memcapacitors, another class that contains inductors and meminductors, and another class that contains *both* resistors and memristors. That is the strongest argument against the "4th element" idea: Chua's own paper puts resistors and memristors into the *same* class of elements.

You may have noticed that I mentioned only 3 of the 4 classes in the periodic table. That's right, there *is* a 4th class of devices that you've never heard discussed, but it's not memristors!

> *Does Chua still theorize that the memristor is a fourth circuit element?*

Yes, he is still sticking by that as of 2003 at least. If you want to call memristors the 4th, memcapacitors the 5th, meminductors the 6th, then you are forced keep going through the entire periodic table and talk about the 7th, 8th, and so on up to infinity. That's fine. However, you can not say that a memristor is as different from a resistor as a capacitor is from an inductor - that's not true. And you can see that it's not true by looking at Chua's own periodic table.

<http://www.frogheart.ca/?p=898>

Some more hints

"Short for memory resistance, memristance is a property of an electronic component that lets it remember (or recall) the last resistance it had before being shut off."

<http://www.webopedia.com/TERM/M/memristance.html>

"It appears that the defining feature of the memristor is that it has some memory of the past current so that the memory resistance is a function of *both present and past* current rather than just current.

"Also, V is always a "difference", I mean, its always really dV , its referenced to something, right? Just from where you measure it makes a difference."

"In the case of linear elements in which M is a constant, memristance is identical to resistance. However, if M is itself a function of q yielding a nonlinear circuit element, then no combination of resistive, capacitive, and inductive circuit elements can duplicate the properties of a memristor.

"The most important lesson for students to learn from this note is that the familiar Ohm's law $v = iR$ is merely an approximation which is inadequate for a nonlinear circuit."

http://www.veneermagazine.com/01-18/05/the_group/memristor.html

1.4. Generalizations

Circuit elements with memory: *memristors*, *memcapacitors* and *meminductors*

"This relation can be generalized to include any class of two-terminal devices (which are called memristive systems) whose resistance depends on the internal state of the system."

"We extend the notion of memristive systems to capacitive and inductive elements, namely capacitors and inductors whose properties depend on the state and history of the system. All these elements show pinched hysteretic loops in the two constitutive variables that define them: current-voltage for the *memristor*, charge-voltage for the *memcapacitor*, and current-flux for the *meminductor*.

We argue that these devices are common at the **nanoscale** where the dynamical properties of electrons and ions are likely to depend on the *history* of the system, at least within certain time scales.

These elements and their combination in circuits open up new functionalities in electronics and they are likely to find applications in neuromorphic devices to simulate learning, adaptive and spontaneous behavior.

Many systems belong to this class, including the thermistor (whose internal state depends on the temperature). In particular, memristive behavior is a property of thermistors, molecular systems, spintronic devices and thin film nanostructures."

"In fact, it should not come as a surprise that many of the above examples refer to nanoscale systems, whose resistance is likely to depend on their state and dynamical history, at least within (possibly very short) times scales dictated by the fundamental state variables that control their operation."

<http://arxiv.org/pdf/0901.3682v1>

<http://nanomorphware.blogspot.com/2009/02/missing-memcapacitor-found.html>

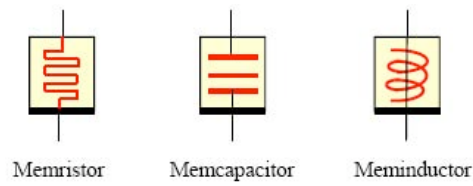

Simulations don't become realizations (Pattee)

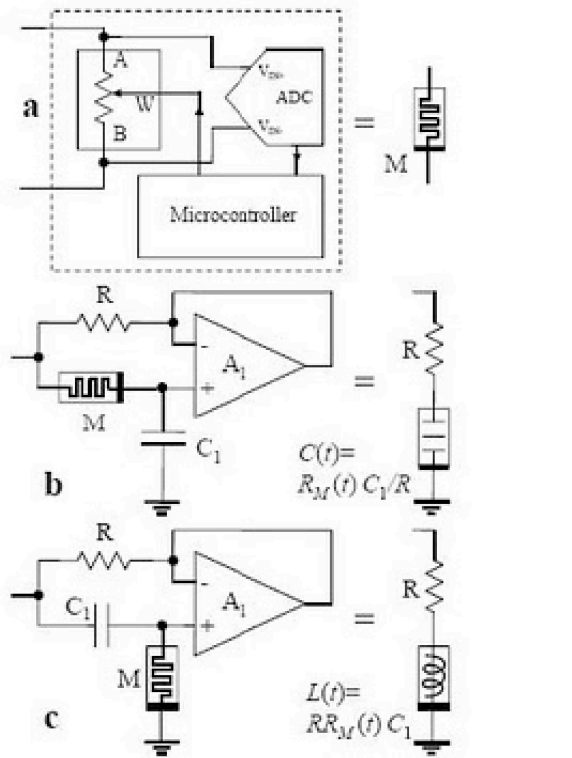

Fig. 1. Circuits simulating (a) memristor, (b) memcapacitor and (c) meminductor. Their approximate equivalent circuits are shown on the right.

2. Aesthetics and ontology of memristance

2.1. Aesthetics turned nano-technological

With this complementation by a fourth element not only the aesthetical symmetry is reinstalled but there is, nevertheless, an irritating asymmetry introduced too, in Chuan's discovery, still confusing people and nourishing strategies of retreat:

"But the hypothetical device was mostly written off as a mathematical dalliance."

The trinity holds perfectly for the micro-world but the fourth element is not an element at all, it is not based on an entity-ontology but belongs to a process paradigm of the nano-sphere. That is, the trinity is mathematically, bravely, *linear*, the fourth dimension is strictly *non-linear*, and is represented more by "pathological" and queer functions, now yet well studied by complex systems theory, than by acclaimed linearity. Also the logics of the nanospere is different to the micro-logic which is still ruled by the law of identity and its *inscription* into the dead matter of silicon.

One well known strategy of *domesticating* a radically new idea back home under the umbrella of the holy trinity is to generalize it, and to reduce it to historic forerunner.

As a result of generalization, there is not simply a memristor as a fundamentally new element to observe, there is now a general *memristive systematics elaborated* with a memristive systems theory, and additionally to the memristor we get all the other mem-XY (mem-capacitor, mem-inductor, memthermistor, etc.) as new devices.

Nothing against generalizations and historical studies! But I have the feeling that governmental and cooperate pressures on the scientists is again extremely strong and is not allowing the scientists a reasonable multi- and transdisciplinary conceptual analysis of what is going on.

*"Since our brains are made of memristors, the flood gate is now open for **commercialization** of computers that would compute like human brains, which is totally different from the von Neumann architecture underpinning all digital computers," said Leon Chua*

<http://www.appliancemagazine.com/news.php?article=1383014&zone=0&first=1>

That's great! But how often did we hear such promises and how often have research resources been canalized to fund unfounded belief systems.

I will try to do some work in this direction of critical conceptualizations and formalizations. But now, this blog-entry simply serves to give some *hints and thoughts* about a technological revolution *in status nascendi*.

"The vision for the Systems of Neuromorphic Adaptive Plastic Scalable Electronics (SyNAPSE) program is to develop electronic neuromorphic machine technology that scales to biological levels."

<http://www.darpa.mil/dso/thrusts/bio/biologically/synapse/index.htm>

About SyNAPSE

"First the facts: SyNAPSE is a project supported by the Defense Advanced Research Projects Agency (DARPA). DARPA has awarded funds to three prime contractors: HP, HRL and IBM. The Department of Cognitive and Neural Systems at Boston University, from which the Neurdon's hail, is a subcontractor to both HP and HRL. The project launched in early 2009 and will wrap up in 2016 or when the prime contractors stop making significant progress, whichever comes first. 'SyNAPSE' is a backronym and stands for Systems of Neuromorphic Adaptive Plastic Scalable Electronics. The stated purpose is to "investigate innovative approaches that enable revolutionary advances in neuromorphic electronic devices that are scalable to biological levels."

<http://www.neurdon.com/about-synapse/>

A brief history of the memristor: from Leon Chua, to HP, to Boston University

<http://www.neurdon.com/2009/07/08/leon-chua-and-the-memristor/>

2.2. Process ontology

Flux and charge

"According to Chua's theory, the memristor is a device as fundamental as the resistor, inductor and capacitor, but is based on the *relationship between flux and charge*, rather than between voltage and charge."

"In 2008, when HP demonstrated the first memristor, Chua said the shift from a voltage-charge paradigm to one *based on flux and charge* is as dramatic as the shift from the Aristotelian to the Newtonian concepts of physics."

http://www.zdnet.co.uk/news/emerging-tech/2010/04/09/memristor-discovery-could-lead-to-faster-hpc-40088582/?s_cid=938

Chiasm of computation as memory and memory as computation

My interests are supporting the elimination of glue. Glue is a metaphor for resource consuming devices which are not producing anything, like buffers, busses, connectors in the context of computation and computational interactivity. <http://www.thinkartlab.com/CCR/2009/01/category-glue-ii.html>

Memristors could make CPUs and RAM obsolete

By Rick Burgess, TechSpot.com

"The harder (but even more efficient) architecture change will be true melding of logic and memory, creating a processor that computes and stores simultaneously."

<http://www.techspot.com/news/38536-Memristors-could-make-CPU-and-RAM-obsolete.html>

'Memristive' switches enable 'stateful' logic operations via material implication

"Here we show that this family of nonlinear dynamical memory devices can also be used for logic operations: we demonstrate that they can execute material implication (IMP), which is a fundamental Boolean logic operation on two variables p and q such that $pIMPq$ is equivalent to $(NOTp)ORq$. Incorporated within an appropriate circuit, memristive switches can thus perform **'stateful' logic operations for which the same devices serve simultaneously as gates (logic) and latches (memory)** that use resistance instead of voltage or charge as the physical state variable."

<http://www.nature.com/nature/journal/v464/n7290/full/nature08940.html>

From a logical point of view this decision for "*material implication*", the concept of which Williams found on the first 7 pages of the monumental work of Russell/Whitehead, as " $(NOTp)ORq$ ", sounds very weak and is not in the tradition of constructive logics applied today in computer science in the context, say, of Linear Logics. At Russell's we can learn: $(X \rightarrow Y) \rightarrow Y \equiv (X \vee Y)$ (Russell, 1903). To define more logical connectives, *negation* is necessary.

Logical implication is an important connective in logic but an introduction by classical logical negations, as " *$pIMPq$ is equivalent to $(NOTp)ORq$* ", is an unnecessary reduction to a classical ontological position which is not in accordance with process-oriented approaches.

Computational logic at Girard's:

<http://iml.univ-mrs.fr/~girard/linear.pdf>

material implication, again

"The work [on memristors, rk] is based on the existing knowledge that the full set of logic operations can be performed using a combination of NAND (not-and) gates. The new work demonstrates that it's possible to build a NAND gate using a combination of three memristors, but only if you use a frequently overlooked logical operation called "*material implication*." As the authors describe it, for Boolean states p and q , a material implication is " p implies q "—if p is true, then q must also be. The work shows that it's possible to build an IMP logic gate using two memristors combined with a standard resistor; add a further memristor that acts as a *false* operation (it always returns false), and you get a complete set of logic operations."

<http://arstechnica.com/science/news/2010/04/complete-logic-set-performed-using-memristors.ars>

"implication—a "complete" operator that can be interconnected to create any logical operation, much as early supercomputers were made from NAND gates. Bertrand Russell espoused material implication in *Principia Mathematica*, the seminal primer on logic he co-authored with Alfred Whitehead, but until now engineers have largely ignored the concept."

http://www.eetindia.co.in/ARTP_8800603645_1800009.HTM

It is also well known in logic that there is no chance to build the whole set of binary logical connectors out of logical implication only. The trick applied is to represent material implication by "*not p or q*" which includes negation.

Because its properties are not intuitive at all, material implication has initiated a bulk of logical, linguistic and philosophical interpretations, around the topic of the *paradoxes of implication*.

"It has been shown that memristors are naturally suited for performing implication logic (combination of implication and false operation) instead of Boolean logic. Also, it should be noted that a memristor can be used as both a logic gate and a latch (stateful logic). Being functionally *complete*, implication logic can be used to compute any Boolean function."

Lehtonen, E. Laiho, M., Stateful implication logic with memristors, IEEE/ACM 2009

Hence, again, it is logical (material) *implication* and *negation* which is allowing completeness. There is no completeness in propositional logic with implication only. Non-Boolean logics are of importance in Quantum Mechanics but a logic based on the implication IMP is still Boolean.

The bulk of papers, repeating each other is growing very fast. Hence my little report has to stop the journey at this point of development.

One more of the same, even with an acceleration from logic to a new logic:

A new kind of logic(?)

"Most silicon transistors perform a full set of logic operations using a combination of NAND (not-and) gates. Previously, it was thought that memristors will not be able to perform a full set of logic operations. But, it has now been found that a memristor can also be made to transfer its state to other memristors, therefore producing devices that can reprogram themselves in a manner that depends on the evaluation of other logic operations. Memristors can hence use NAND gates for logical operations, but in a new way, with a combination of three memristors using a logical operation called "material implication", where for Boolean states p and q , a material implication is " p implies q ", and if p is true, then q must also be."

http://www.thinkdigit.com/CPUs-Motherboards/HPs-memristors-are-a-whole-new-breed_4382.html

It is at least misleading jargon to talk about a "*new logic*". Propositional logic based on material implication plus negation is equivalent to a choice of negation plus conjunction, i.e. NAND. As it is said correctly, "*Boolean logic operation on two variables p and q such that $p \text{IMP} q$ is equivalent to $(\text{NOT} p) \text{OR} q$* ", this is obviously not another logic but another *implementation* of the same logic. Instead of the common NAND, IMPL plus NEG is used. From the engineering point of view, e.g. of gate arrays and integrated circuits, this makes in fact a big difference.

Simultaneously "as"

As usual, interesting concepts are introduced using the particle "**as**", e.g. in "*'stateful' logic operations for which the same devices serve simultaneously **as** gates (logic) and latches (memory)*". The other 'passe-partout' is the word "**simultaneously**". Both don't get a proper scientific explanation and formalization in the propagated theories.

A transdisciplinary approach would make it clear that there is no necessity that such 'passe-partouts' have to remain "dummies".

Epistemology of memristors and memristance

A supplementation of the triple or trinity of (resistor, capacitor, inductor) is not a *quantitative* addition to the fundamentals of electronics but is transforming the whole conceptual framework of the classical electronics in its fundamentals.

At *first*, the quadruple, replacing the triple, is producing a higher form of abstraction of the origin triple as such. Like in a categorification (John Baez), the definition of the operands as entities of the triple, (resistor, capacitor, inductor), are becoming secondary and the functionality (process character) enters into the focus.

Categorification, at first, means, the math of Boolean circuits has to be transformed from calculus to categories.

This happens as a straightforward abstraction.

The *set* of elements {resistor, inductor, capacitor} is categorified to “*objects*” of a category. The *equation* between elements becomes “(iso)*morphisms*” between objects. Hence, sets are transformed to “*categories*”, *functions* become “*functors*” and *equation* become “*natural transformations*”.

Hence, the definition of inductors, resistors and capacitors are changing by a conceptual transformation from the status of *entities* and their properties into the status of *second-order conceptions* of ‘inductivity, resistivity and capacitivity’.

<http://www.thinkartlab.com/pkl/lola/Categories-Contextures.pdf>

M as a constant and as a function

"In the case of linear elements in which M is a constant, memristance is identical to resistance. However, if M is itself a function of q yielding a nonlinear circuit element, then no combination of resistive, capacitive, and inductive circuit elements can duplicate the properties of a memristor." (Frank Y. Wang)

Categorification of electronics is still at the very beginning.

"Is there a categorification of the Memristor in those analogous domains?"

http://golem.ph.utexas.edu/category/2010/01/this_weeks_finds_in_mathematic_51.html

Categorification, *secondly*, means, as a consequence of the conceptualization (categorification), that the functionality of inductivity, resistivity and capacitivity are not ontologically fixed anymore to a physical domain but are distributed over all positions of the quadruple. Hence, the

functionality of the memristor is itself not localized at a single position but is able to realize all the other functionalities in the context of the whole quadruple.

In other words, the fact that the memristor is able to realize the functions of the triple (mem-capacitor, mem-inductor) doesn't mean that they are becoming obsolete and the memristor is the new and unique instance of electronics. The memristor is a functionality of *second-order* level and is realizing as memristor the triple functionality (mem-ristor, mem-capacitor, mem-inductor).

Hence, the memristor as a memory functionality is realizing memory, the memristor as computation is realizing computing, etc.

Kraemer's conceptual graph

An attempt to categorification and "semiotization" might get proper support by Thomas Kraemer's complete triadic diagram of "voltage". This diagram is not just a visualization as other diagrams but a consistent triadic *conceptual graph* of the whole constellation. With my next paper to memristics, I will give more conceptual and mathematical analysis involving category and diamond theoretic approaches.

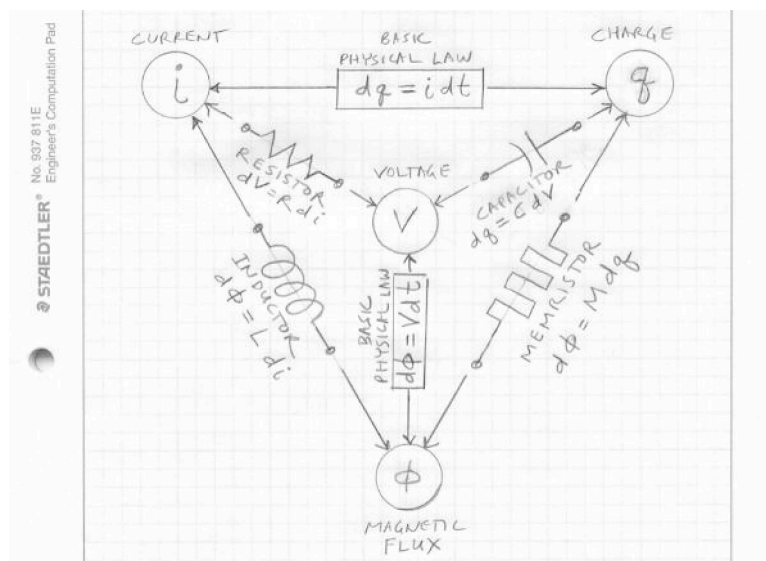

"Thomas Kraemer's visualization of the mathematical relationship between four circuit elements (resistor, capacitor, inductor and memristor) and four circuit quantities (voltage, current, charge and magnetic flux). Of the six mathematical relationships shown, four are represented by circuit elements and two by basic physical laws. To understand memristors better, I drew my diagram as a triangle instead of the square diagram."
<http://thomaskraemer.blogspot.com/2008/05>

Stateful logic

"In a study this week in *Nature*, researchers with Hewlett-Packard report that they've achieved "*stateful logic*" with their memristor, whose name derives from a mashup of "memory" and "resistor." In a nutshell, stateful logic means that the 'state' of the memristor acts as both the computer and the memory.

That's a pretty big change from current computers, which typically load data from memory, perform operations on it, and then send it back.

In addition, memristors can store information even in the absence of electrical current."

Memristors Getting Closer to Ultra-Fast, Brain-Like Computing, Says HP

<http://blogs.discovermagazine.com/80beats/2010/04/09/memristors-getting-closer-to-ultra-fast-brain-like-computing-says-hp/>

Therefore, the triple functions are not becoming superfluous or obsolete, they are fully contained in the new constellation in form of their functionality. Hence, they are even becoming more distinct because they are liberated from their material limitations. The memristor as the fourth component of the complexion is in itself localized on a higher order of abstraction. This is first reflected in the scale. The triple is in the chain of electric, electronics and microelectronics, while the memristor is on the level of nano-"electronics". Hence, the *functionality*, not the entities, of the electronic triple gets transferred to the nanosphere too.

Chiastic interactivity

It would be a misunderstanding to think that the memristor is replacing the triple. It is replacing the entity-type realization of the triple function and not their functionality.

Hence, the simultaneity of memory and logical computing functions of the memristor have to be realized in a new concept of interaction, interplay, not known to the triple because of its lack of functional abstractness.

The memristor is not yet solving the problem how both functionalities, computation and memory, are realized in concreto. The memristor is the necessary condition but only the *interactions* between different memristors are able to realize such a simultaneity. It is not the identical stuff at the same time and at the same place that is both at once, computation and memory, but the chiastic interactivity of both functionalities together, creating their own time and identity.

Hence, the whole mechanism is conceptually and physically working only with the as-abstraction of second-order conceptuality and not with the is-

abstraction of entity-ontology.

<http://works.bepress.coma/thinkartlab/2/>

Again, what's about and how does it work?

CPUs to be phased out by configured memristors

"HP realized the material implication gate with one regular resistor connected to two memristors devices used as digital switches (low resistance for "on" and high resistance for "off"). By using three memristors, HP could have realized a NAND gate and thus re-created the conditions under which earlier supercomputers were conceived. But HP claims that *material implication* is better than NAND for memristor devices, because material implication gates can be cast in an architecture that uses them as either memory or logic, enabling a device whose function can be dynamically changed.

"Memristor innovator Stan Williams, a senior HP fellow and director of its Information and Quantum Systems Lab, claims that dynamically changing memristors between memory and logic operations constitutes a new computing paradigm *"enabling calculations to be performed in the same chips where data is stored, rather than in a specialized central processing unit."*

http://www.tinned.co.in/ART_8800603645_1800001_NT_6f3e9de0.HTM

Further clarification by Stanley Williams:

"The issue is that in Chua's definition of a memristor [7] , there are *two crucial equations* needed to model the behavior of the device: One the *static* conduction equation that shows that the resistance of the memristor depends explicitly on a *"state variable"* and, the other, which is what clearly differentiates the memristor from any other device, the *dynamical* equation that explicitly expresses the time dependence of the state variable as a function of the current through the device.

"The most important insight we had was to identify the time derivative of the state variable as the drift velocity of dopants (in our case, oxygen vacancies, but in other cases, this could be other dopants or the lead and silver ions in [1]), which enabled us to write down, for the first time, an expression for the memristance of a physical device in terms of its geometrical and material properties."

Williams RS. Reply to - "On the Discovery of a Polarity-Dependent Memory Switch and/or Memristor (Memory Resistor)". IETE Tech Rev

[serial online] 2010 [cited 2010 May 16];27:181-2. Available from: <http://tr.ijetjournals.org/text.asp?2010/27/2/181/60171>

2.4. Further speculative dalliances

Complementarity of memristors and compuristors

Therefore a complementary concept to the functionality of the memristor has to be achieved. The complementary term to “*memristor*” shall be called “*compuristor*”.

How can a memristor “*act as a logic and as a memory device if it is by definition a passive two-terminal electronic device*”?

“An ideal memristor is a passive two-terminal electronic device that is built to express only the property of memristance (just as a resistor expresses resistance and an inductor expresses inductance).”

Hence, what is interacting in the wording of “‘memristors’ can also perform a fundamental class of logic operations that requires “**individual devices to act simultaneously as logic and memory elements**” is neither a memristor nor a computational element, defined in the classical microelectronic way, but a new mechanism of interaction between both.

“If memristors can perform logic, they might one day be used to create computer processors, suggests Williams.”

<http://www.hpl.hp.com/news/2010/apr-jun/memristor.html>

That is, the observed simultaneity of memory and computation in *crossbar architectures* is not well conceived within the old computational paradigm and the new concept of memristance. The old computational concept is still defined in terms of a micro-technology while memristance is defined in terms of nano-technology.

Nanotechnology still lacks, like quantum mechanics, a reasonable logico-mathematical formalism.

New approaches to a better understanding of quantum processes are introduced by Abramsky and Coecke in the framework of monoidal categories. But their quantum approach is supporting a different trend: Quantum Computing in contrast to the *biological* paradigm of memristive systems theory.

web.comlab.ox.ac.uk/people/Bob.Coecke/ctfwp1_final.pdf

Nonreducibility and complementarity

Again, it has to be considered that the memristor concept is not reducible to the classic electronic functions. That is, it is mathematically and practically not possible to define a memristor and its memristance in terms of the holy trinity only.

This seems to be in conflict with the statement “3 Memristors to make a NAND gate 27 NAND gates to make a Memristor”. This, again, seems to be a category mistake between *emulation* and *simulation*.

Hence, as usual in quantum mechanics of the nanosphere, *complementarity* has to be considered, theoretically and realized practically.

Computability and memristive systems

“This constant cannot be removed by subtracting a constant from $x(t)$ and remains after differentiating $x(t)$ with time. Therefore, memristor response depends on *history*.” (Frank Y. Wang)

http://www.veneermagazine.com/018/05/the_group/memristor.html

$$\frac{d}{dt}x(t) = \frac{v_0}{\beta} \frac{\sin(\omega t)}{\sqrt{r^2 + 2(r-1) \left[\frac{v_0}{\beta \omega} \cos(\omega t) + c \right]}} \left[= \frac{R_{em}}{\beta} i(t) \right] \quad (14)$$

Depending on *history*, defined as *second-order* concepts, main prerequisites for algorithmic modeling and computation are disappearing. From a conceptual point of view, it also seems to be questionable to model memristive systems still with the machinery of non-linear mathematics (of complex systems).

Hence, stripped to the bones, the fourth principle of electronics is a realization of the category “history”.

Therefore, memristance appears in different forms, like mem-capacitance, mem-inductance, inside nanoelectronics, and others outside of electronics.

Zillions

It also has to be clear that the fourth element completing the systematics of electronics is not an arbitrary one of “zillions”.

“Another question: why did Leon Chua focus attention on this particular 1-port? There are, after all, zillions of options besides this and the 5 that I listed (resistance, capacitance, inductance = inertance, voltage source = effort source, and current source = flow source).

http://golem.ph.utexas.edu/category/2010/01/this_weeks_finds_in_mathematic_51.html

Memristors and compuristors

Thus, the missing process, which is not an element, but the *complementarity* of the processuality of the memristor is a “compuristor”, i.e. the computational function of memristance, hence “compuristance”. This is not just a word game, albeit the terminology is probably only very temporary. But the hint is clear, it is a category mistake to speak in the context of memristors and memristance of a *simultaneity* of memory and computation without deconstructing and transforming the terminology and the concepts towards the new level of nanotechnological devices.

It seems that the whole misery would be restarted and continued, albeit on a higher level, if the complementarity of nano-computation would be conceptualized and technically realized as a mix of classical micro-electronic transistor technology and memristive nano-technological devices.

We should urgently *separate* research and developments of the new chances of scientific discoveries and inventions from the pressure of big companies and institutions, civil and military.

There is no doubt at all that the last and most recent neuro-boom would have been much more successful if it wasn't dominated by non-scientific pressures and an academic denial of approaches and results in other disciplines.

A good memory for logic

<http://www.nature.com/nature/journal/v464/n7290/edsumm/e100408-06.html>

What we need now is not only “*A good memory for logic*” but as well and at once “*A good logic for memory*”.

An ultimate achievement for a memorization of both, logic and memory beyond goodness, might be realized by a Mexican funeral of both: memory and logic.